



MODEL EX / EXE



## Actuated Valves & Self-Contained Hydraulic Control Systems

Zero emission ESD solutions for surface safety, HIPPS and other energy production, distribution and storage applications.

Exceptional protection for facilities, personnel and the environment.



- API 6A Monogrammed Hydraulic Safety Valves
- Completely Self-Contained for Zero GHG Emission
- Configured Based on Customer & Site Requirements
- Engineered for Years of Trouble Free Service

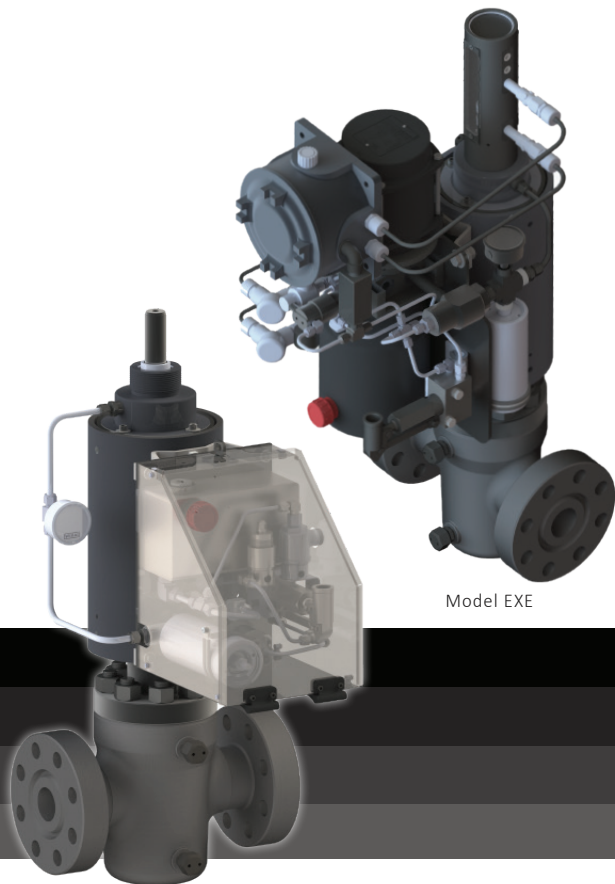

Model EXE

Model EX



## Self-Contained Hydraulic Control Systems for Zero Emission ESD Applications

### Introduction

The Omni Model EX and EXE are self-contained hydraulic control systems used to provide fail-safe valve shutdown capability in emergency conditions. Both models control the actuator while releasing no emissions to the atmosphere. The hydraulic fluid is recycled in a sealed loop and continually re-used, providing excellent environmental protection.

The system consists of a reverse-acting gate valve with Model HX hydraulic actuator and a Model EX or EXE hydraulic control system.

The Model EX energizes the actuator via manual pump. The Model EXE utilizes an electric motor to energize the actuator, while also incorporating a manual pump that can be used to energize the actuator in situations when no power is available. Both systems have a variety of options and can be configured to provide site-specific ESD capability.



### Features- Model HX Actuator & Reverse-Acting Gate Valve

#### Flexibility

Models HX actuators are typically used with Omni Model CS-R or FS-R reverse acting gate valves but can be adapted to operate valves from any manufacturer with appropriate valve interface information.

#### Over-Pressure Protection

Models HX actuators come equipped with pressure relief devices to protect personnel and guard against damage to the actuator in case of an over pressure condition. The pressure relief device is easily inspected and is field-replaceable.

#### Non-Pressurized Actuator Housing

Model HX actuators have outer housings that are structural and protective only – they are not under hydraulic pressure. This helps protect personnel and equipment in the event of damage to the outer housing.

#### Backseat & Packing Integrity

Model HX actuators incorporate bonnet assemblies that have an integrated metal-to-metal backseat. A bonnet fitting can also be used to relieve any pressure that might be trapped between the backseat and stem packing after the backseat operation.

#### Corrosion Protection

Models HX actuator housings are internally and externally coated to prevent corrosion due to environmental conditions. All internal components are either stainless steel or are coated to prevent corrosion.

#### Maintenance

Models HX actuators are designed for ease of maintenance. All non-metallic seals and other parts are easily replaceable. Omni stocks redress kits for all Model HX actuator sizes.

#### Gate Valve Trims

Model CS-R and FS-R gate valves are available in most API 6A material classes, product specification levels (PSL) and performance ratings (PR).





## Model EX: Manual Operation Only

### Introduction

The Omni Model EX is a self-contained hydraulic control system designed to control hydraulically-actuated surface safety valves. Model EX systems are designed to provide fail-safe ESD capability, are rugged, compact and easy to access in a field service environment. Components are designed to perform well and provide years of trouble free service even in the harshest of operating conditions.

The system energizes the actuator using its own hydraulic fluid reservoir. There is no need for access to a hydraulic power source at the well site or wherever the actuated valve is deployed. This makes it ideally suited for deployment in remote locations or locations with limited power source options.



### Options

- High or Low Pressure Pilots (or both)
- Solenoid Valve (12, 24 or other vdc electric)
- Combination of Pilots and Solenoid
- Connectivity to SCADA or Other Controls
- Integrated Position Indication (Limit Switches)

### Availability

The Model EX system is most commonly deployed as a complete valve/ actuator/ control system package using Omni Valve's complete line of failsafe hydraulic valves; however, the system can also be easily adapted to control hydraulic valves from any valve manufacturer.

### Standard System Specifications

Temperature Range	-20 to 180 °F
Reservoir Capacity	½ gal
Maximum Operating Pressure	3,000 psi

### Features

#### Fully Enclosed Stainless Steel Cabinet with Locking Latch:

Model EX systems bolt directly onto the hydraulic valve actuator and are fully enclosed with a stainless steel hinged cabinet that can be secured in the closed position and locked, if needed.

#### Horizontal or Vertical Mounting:

Model EX systems can be configured for horizontal or vertical mounting.

#### Multiple Pressure-Sensing & Control Configurations:

Model EX systems can be configured in multiple ways depending on the pressure sensing and connectivity requirements of the well site.

#### Ease of Operation:

Model EX system can be easily taken off line or re-started with minimal training.

#### Fusible Link:

Model EXE systems can incorporate a fusible link that will cut the supply pressure to the actuator and allow the safety valve to close in the event of a fire.

#### Zero Power/Off Grid/Remote Configuration:

Model EX systems are capable of being configured in a way that requires zero power to operate. Such a configuration would be completely analog. The only shut down options would be a mechanical pressure pilot system with a local manual shutdown valve.



## Internal Configuration and Overall Dimensions

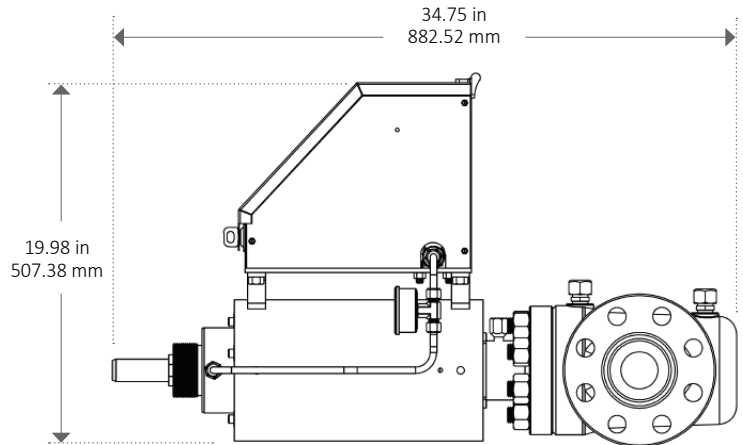
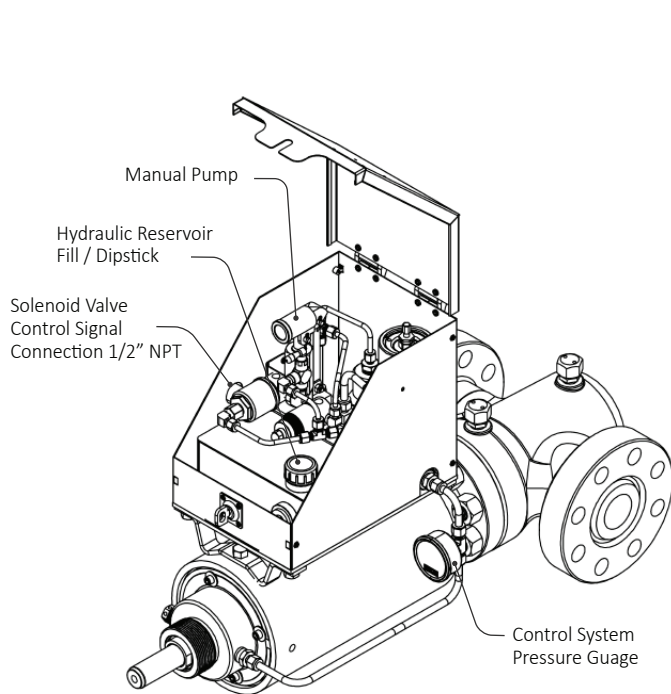

Valve shown installed in horizontal orientation.  
Operating stem and flow bore are horizontal.  
Vertical orientation is also available.

### Installation, Startup and Operation

#### Installation:

Valve installation will require studs, nuts and ring gaskets appropriate for the valve size and pressure class.

Connect applicable power supply to the solenoid leads and check control fluid level using the supplied dipstick. Add fluid if necessary. Appropriate hydraulic fluid is supplied with the unit.

#### Startup:

Apply power supply to the solenoid. Use the supplied manual pump handle to pump the unit up to 2,700 PSI.

This ensures there is appropriate stored energy in the system to account for ambient temperature fluctuations.

#### Basic Operation:

The EX Hydraulic Controller is manually pumped up to create sufficient control pressure in the actuator hold the safety valve in the open position. Two methods can be used to close the valve and shut in the well:

1. Removing power from the electric solenoid will cause the controller to relieve the actuator control pressure. This allows the safety valve to close.
2. The local manual shut down valve located between the regulator and the solenoid valve will relieve the actuator control pressure and allow the safety valve to close.

#### Emergency Shut Down:

Remove solenoid power. Opening the manual shut down valve located inside the cabinet will release the control pressure.

Once the valve has been closed, it can be brought back on line using the startup procedure.

## Model EXE: Electric Operation (Primary) & Manual Operation (Backup)

### Introduction

The Omni Model EXE is a self-contained hydraulic control system that utilizes electric power to control hydraulically actuated surface safety valves. Model EXE systems are designed to provide fail-safe ESD capability, are rugged, compact and easy to access in a field service environment.

Components are designed to perform well and provide years of trouble-free service even in the harshest of operating conditions. The system is normally energized by an electric motor-driven pump, but has a manual pump that can be used in case power is lost.

### Availability

The Model EX system is most commonly deployed as a complete valve/ actuator/ control system package using Omni Valve's complete line of fail-safe hydraulic valves; however, the system can also be easily adapted to control hydraulic valves from any valve manufacturer.

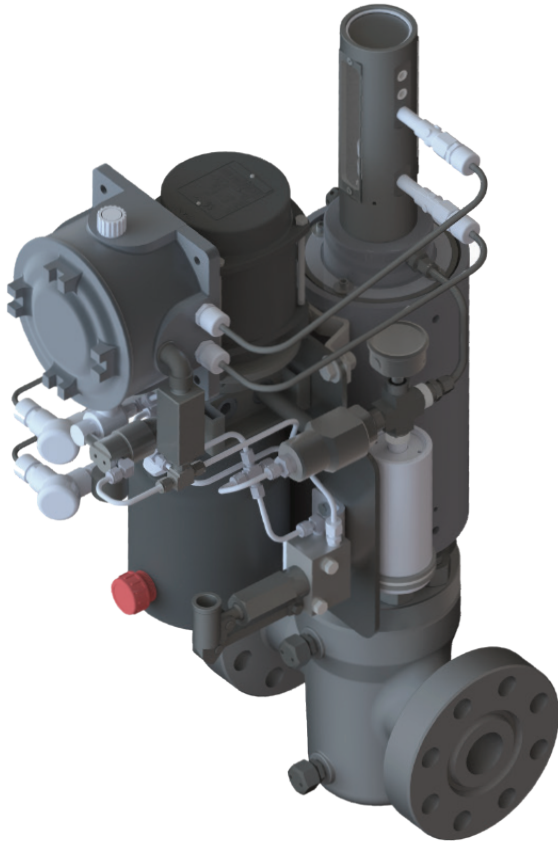

### Options

- High or Low Pressure Switches (or both)
- Solenoid Valve (12, 24 or other vdc electric)
- Customizable ESD Logic
- Integrated Position Indication (Limit Switches)
- Connectivity to SCADA or Other Controls, Including
  - Programmable Logic Controllers
  - Remote Terminal Units
  - Local Operator Interfaces

### System Specifications

Temperature Range	-20 to 180 °F
Reservoir Capacity	1 gal
Maximum Operating Pressure	3,000 psi
Electric Motor	Variable Max Amp, 1.8 watt continuous

### Considerations for Determining System Configuration

1. The size of actuator to be stroked (reservoir size)
2. Available power supply (AC/DC and voltage)
3. Acceptable amperage draw at peak and during hold open
4. Operating run times (time required to open the valve)
5. The addition of a separate signal line to operate the unit
6. Hazardous location requirements (certifications required)

### Features

#### Connectivity:

Model EXE systems can be operated remotely, via logic controller or SCADA system.

#### Operation:

Model EXE systems are primarily operated electrically but have manual pump backup.

#### Horizontal or Vertical Mounting:

Model EXE systems can be configured for horizontal or vertical mounting.

#### Multiple Pressure-Sensing & Control Configurations:

Model EXE systems can be configured in multiple ways depending on the pressure sensing and connectivity requirements of the well site.

#### Ease of Operation:

Model EXE systems can be easily taken off line or re-started with minimal training.

#### Fusible Link:

Model EXE systems can incorporate a fusible link that will cut the supply pressure to the actuator and allow the safety valve to close in the event of a fire.



## Internal Configuration and Overall Dimensions

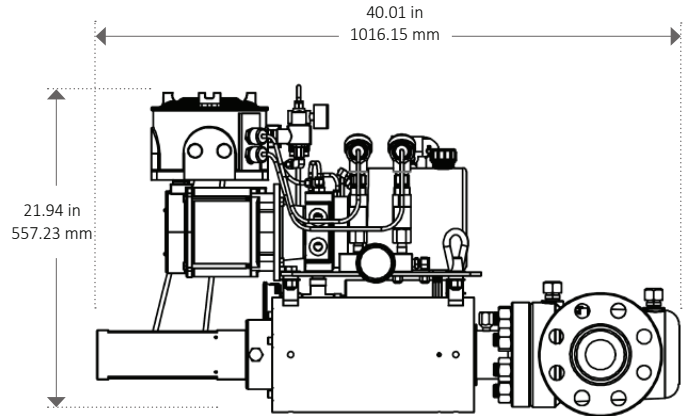
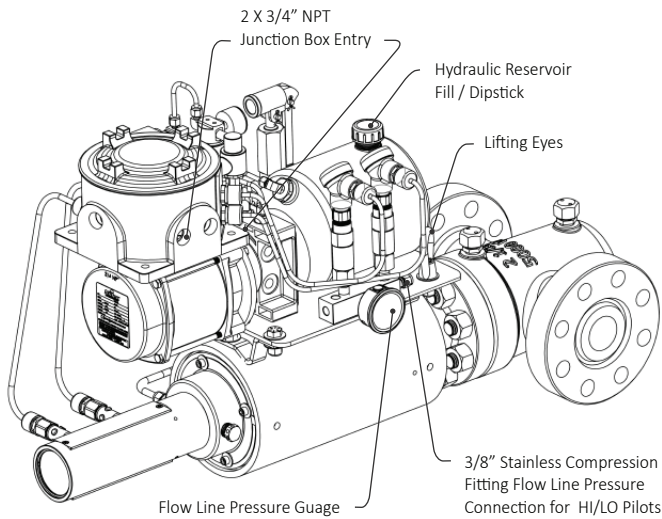

Valve shown installed in horizontal orientation. Operating stem and flow bore are horizontal. Vertical orientation is also available.

Note: Valve shown with optional limit switch and high/low pressure switch modules.

## Installation, Startup and Operation

### Installation:

Valve installation will require studs, nuts and ring gaskets appropriate for the valve size and pressure class.

Connect applicable power supply to solenoid leads and fill reservoir with hydraulic fluid. Appropriate hydraulic fluid is supplied with the unit.

### Startup:

Specific procedure will vary depending on integrated ESD logic options.

Complete startup documentation will be provided based on specific system configuration.

### Basic Operation:

The EXE Hydraulic Controller is powered by an electric motor that creates sufficient control pressure in the actuator hold the safety valve in the open position. If no power is available, the actuator can also be energized via manual pump.

### Emergency Shut Down:

Note: ESD parameters will depend on specific system configuration. However, with utilization of pressure switches, the following events will cause the safety valve to close and the well to be shut in:

1. Removing power from the electric solenoid and motor will cause the controller to relieve the actuator control pressure. This allows the safety valve to close.
2. The local manual shut down valve will relieve the actuator control pressure and allow the safety valve to close.
3. Exceeding high or low pressure switch settings will relieve the actuator control pressure and allow the safety valve to close if pressure switches are being utilized.

Once the valve has been closed, it can be brought back on line using the startup procedure.



## Standard Components on all Model EX & EXE Systems

### Component

#### Accumulator:

The integrated accumulator is pre-charged with nitrogen to compensate for expansion and contraction of the hydraulic fluid during temperature cycles. This action will allow the control system to maintain constant pressure and remain online during extreme temperature fluctuations of the ambient air. The nitrogen pre-charge pressure, set at the factory, accounts for the fluid volume under pressure and the minimum required hold open pressure. This ensures the control system pressure will not drop low enough to allow any stem creep and eliminates any possibility of valve washout due to partially open valves. The required pre-charge pressure is stenciled on the name plate and can be verified during operation without the use of any special tools or gauges.

#### Solenoid:

Both systems integrate a normally open solenoid to facilitate emergency shut down operation. The solenoids are available in both 12 and 24 vDC and draw 1.8 watts of power. The normally open solenoid ensures the system will relieve pressure from the hydraulic actuator and shut-in the safety valve if the control signal is lost for any reason. Control signal loss can be facilitated by an external SCADA system, emergency shut down station, or any number of integrated ESD features of the system itself. Solenoids utilize a ½" NPT conduit connection and are UL/CSA CL1 DIV 1 rated.

#### QEV:

The integrated Quick Exhaust Valve acts as a shuttle valve that gives the stored fluid volume of the entire system a direct bleed line back to the fluid reservoir. This enables the system to achieve the quickest possible safety valve closing time. This also allows many different custom pilot systems, fusible links, and local manual shutdown valves to be integrated into the system without low working pressure or flow rates affecting the closing time of the safety valve.

#### Pressure Gauge:

Line pressure gauges are supplied with both systems. They are located on the pressure line from the control system to the actuator and are orientated to be visually inspected from a distance. This allows the user to check system status without requiring the cover to be opened or the user to be in very close proximity to the system.

#### Manual Pump:

Both systems utilize the same manual pump. The Model EX system utilizes the manual pump as the primary pressure source to bring the system online and open the safety valve. The Model EXE system utilizes an electric motor/pump as the primary pressure source but has the same manual pump as the Model EX. The manual pump can serve as a backup to the electric pump if there is insufficient (or no) power available to operate the electric motor.

#### Fill Kits:

Both systems are shipped with a fill kit that contains control fluid, installation and startup instructions, a funnel, and rags.

### Optional Equipment

#### Integrated Hi/Lo Pressure Sensors:

Both systems can incorporate pressure sensors that are plumbed into the flow line to sense pressure and initiate ESD (valve shut in) if the flow line pressure drops below or rises above the set pressures of the sensors. These sensors are available in fully electronic or fully analog configurations. Electronic pressure sensors interrupt the supplied control signal to the solenoid valve, which causes the system to allow the safety valve to close. Analog pressure sensors are traditional pilot pressure switches that mechanically bleed the hydraulic pressure from the control system and allow the safety valve to close.

#### Integrated Position Indicators (Limit Switches):

Both systems can incorporate position sensors that can be integrated into SCADA or other on-site data acquisition systems to provide real time valve position information. These sensors are available in a variety of types and hazardous area ratings.







SURFACE SAFETY &  
ISOLATION VALVE SOLUTIONS



MODEL EX / EXE

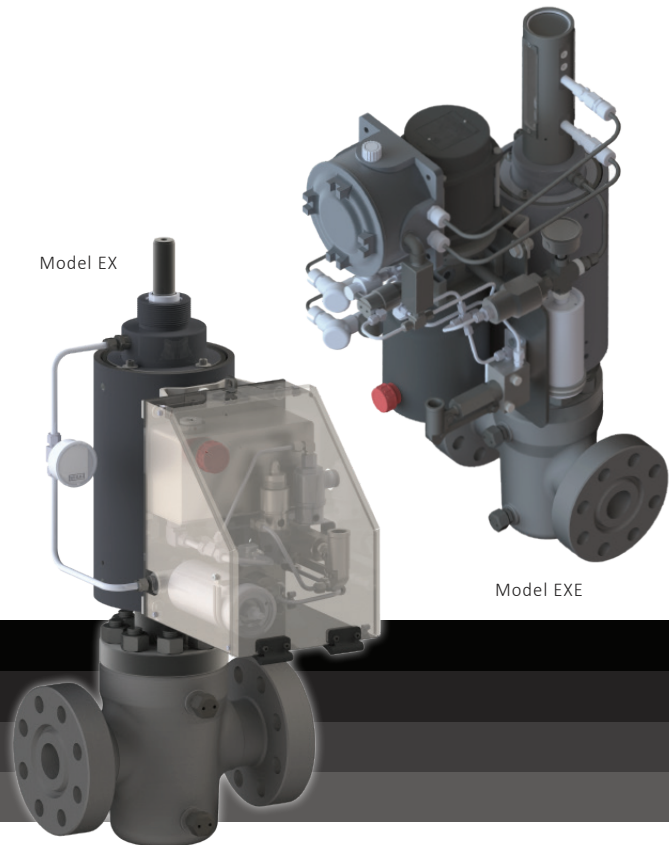

Model EX

Model EXE

Omni Valve

4520 Chandler Road - Muskogee, OK 74403 - USA

-  (918) 687-6100
-  (918) 687-6105
-  sales@omnivalve.com
-  quality@omnivalve.com



**RFQ** REQUEST FOR QUOTE

[omnivalve.com/price-quote-act.php](https://omnivalve.com/price-quote-act.php)

Product Warranty: All products quoted are subject to omni valve's limited product warranty available at: [omnivalve.com/warranty.php](https://omnivalve.com/warranty.php)

