



DIAPHRAGM PNEUMATIC



DX Single



DX Tandem

Model DX

Available in Single & Tandem Configurations

For surface safety and other energy production, distribution and storage applications.

- API 6A Monogrammed
- Highest Quality
- Delivered to Exact Customer Specifications
- Engineered for Years of Trouble Free Service



Model DX - Single & Tandem Configurations

Model DX actuators are designed to operate surface safety or shutdown valves on oil & gas wellhead, transmission, storage, manifold or other applications where fail-safe capability is required. Omni provides API Monogrammed surface safety valve assemblies, or actuator/bonnet assemblies ready to mount on valves from other manufacturers.

Model DX Features

- Available in Single or Tandem Configurations
- Can be Used for land or offshore installations
- Can be adapted to operate valves from any manufacturer
- Engineered to provide reliable service in a variety of operating conditions
- All non-metallic seals and other parts are easily replaceable
- Lightweight and designed for ease of maintenance.

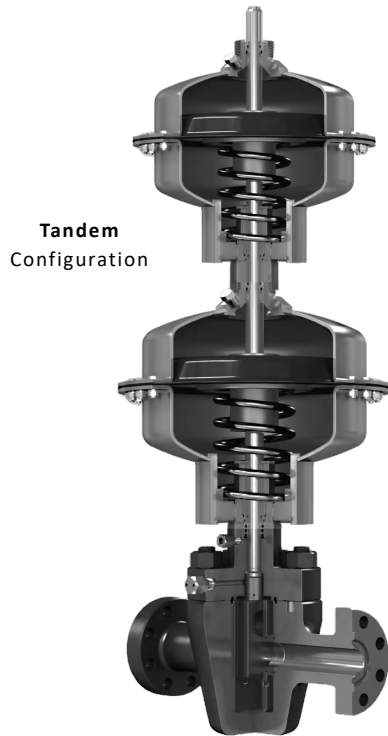
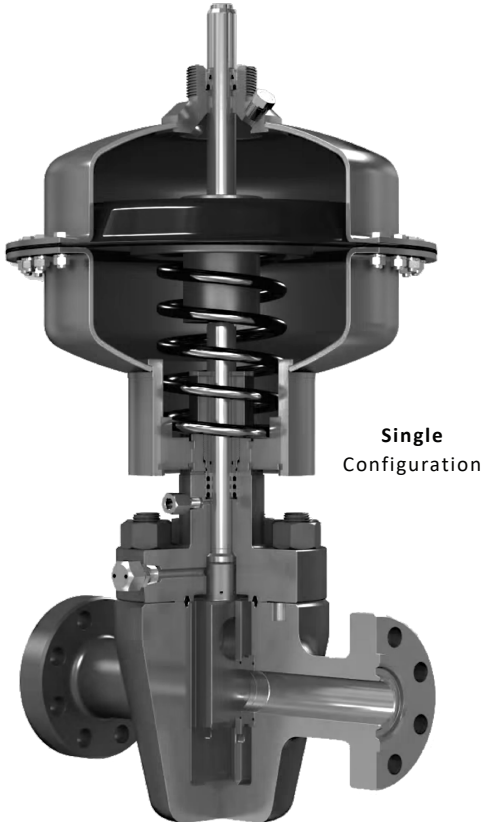

Over-Pressure Protection

The DX comes equipped with pressure relief devices to protect personnel and guard against damage to the actuator in case of an over pressure condition. The pressure relief device is easily inspected and is field-replaceable.

Orientation, Rotation & Ease of Piping

DX Actuators have pressure inlet and outlet ports located at an angle in the top plug assembly to facilitate proper piping orientation based on field conditions. Once proper orientation has been achieved, the actuator's lower bonnet retaining ring can be locked into place to prevent accidental rotation of the actuator while in service.

Backseat & Packing Integrity

The DX actuator incorporates bonnet assemblies that have an integrated metal-to-metal backseat. A bonnet fitting can also be used to relieve any pressure that might be trapped between the backseat and stem packing after the backseat operation.

Corrosion Protection

The DX actuator housings are internally and externally coated to prevent corrosion due to environmental conditions. All internal components are either stainless steel or are coated to prevent corrosion due to any contamination that might be present in the control pressure source.

Available Sizes (Single)		
Model	Size	Stroke
DX-10	10"	Up to 2 ¹ / ₁₆ " bore
DX-12	12"	Up to 3 ¹ / ₈ " bore
DX-15	15"	Up to 4 ¹ / ₁₆ " bore
DX-18	18"	Up to 5 ¹ / ₈ " bore
DX-20	20"	Up to 7 ¹ / ₁₆ " bore

Available Sizes (Tandem)		
Model	Size (upper) / (lower)	Stroke
DX-1212	12" / 12"	Up to 3 ¹ / ₈ " bore
DX-1512	12" / 15"	Up to 3 ¹ / ₈ " bore
DX-1515	15" / 15"	Up to 4 ¹ / ₁₆ " bore
DX-1815	18" / 15"	Up to 4 ¹ / ₁₆ " bore
DX-1818	18" / 18"	Up to 5 ¹ / ₈ " bore
DX-2020	20" / 20"	Up to 7 ¹ / ₁₆ " bore

Model DX Operational Stages



Fail “**CLOSED**” operation is depicted. Fail “**OPEN**” operation is available upon request.

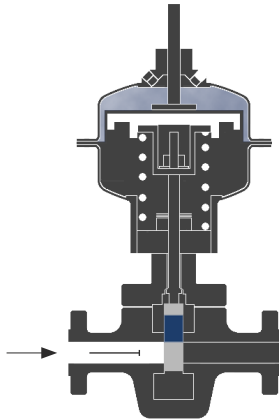

When no control pressure is applied to actuator, valve is in **CLOSED POSITION** (Gate all the way up)

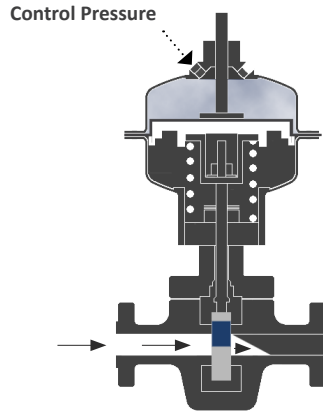

Upon application of adequate control pressure to the actuator, valve begins **OPENING** (Gate moving down)

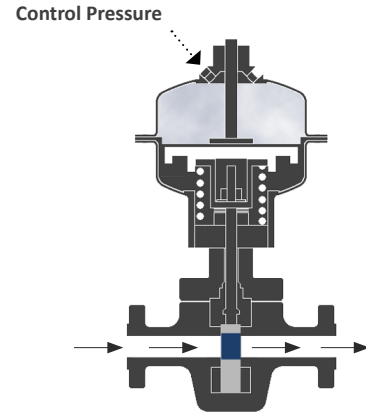

With continued application of adequate control pressure, valve moves to the **FULLY OPEN** position (Gate all the way down)

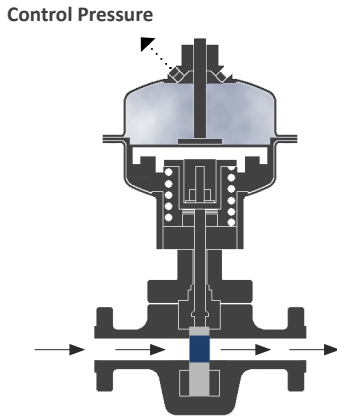

Valve remains in **FULLY OPEN** position as long as adequate control pressure is present (Gate all the way down)

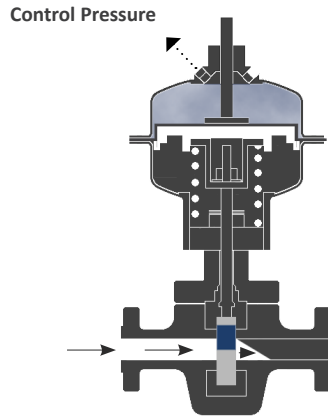

Upon loss of control pressure, valve begins **CLOSING** (Gate moving up)

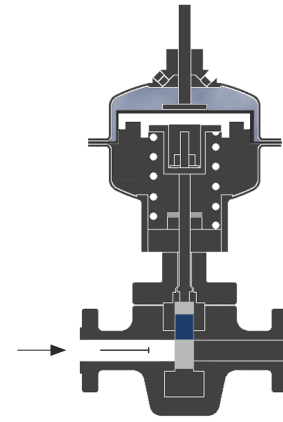

Valve **FULLY CLOSES** & remains closed until application of control pressure to the actuator (Gate all the way up)

Standard Actuator Specifications		
Maximum Operating Pressure	170 PSI	Pressure relief device on actuator is set at 170 PSI
API Material Class	BB	Not appropriate if control source contains H2S (is sour)
API Temperature Rating	P (-20 F to 180 F)	(-29 C to 82 C)

Available in API pressure ratings of between **2,000** and **15,000** psi.

Can be used in conjunction with our **Hydraulic, Pneumatic** or **Electric** actuators from most manufacturers.



Model DX with FS-R or CS-R Gate Valves

Valve Body Specifications

- » Model CS-R and FS-R surface safety valves with Model DX actuators, in single or tandem configurations are available in most API 6A material classes, PSL, PR and Temperature Ratings.
- » Model DX actuator/bonnet assemblies, in Single or Tandem configurations are built to customer specifications and are also available in most API 6A Material Classes. PSL, PR and Temperature Ratings.
- » All Model CS-R and FS-R surface safety valves with Model DX actuators are API 6A 21st Edition monogrammed equipment.
- » All Model CS-R and FS-R surface safety valves with Model DX actuators have successfully passed the API 6AV1 - Validation of Safety and Shutdown Valves for Sandy Service test and can be designated as API 6A-SSV Class 1 or Class 2 for use in Federal Offshore Waters.

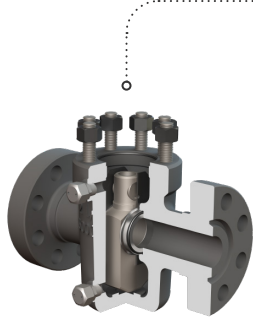

**Model CS-R
Gate Valve**

Bore Size	Pressure (psi)	API Ring #
2 1/16"	2,000	R23
	3-5,000	R24
2 9/16"	2,000	R26
	3-5,000	R27
3 1/8"	2-3,000	R31
	5,000	R35
4 1/16"	2-3,000	R37
	5,000	R39
5 1/8"	2-3,000	R41
	5,000	R44
7 1/8"	2-3,000	R45
	5,000	R46

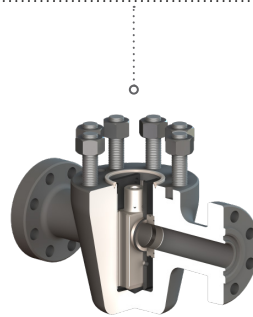

**Model FS-R
Gate Valve**

Bore Size	Pressure (psi)	API Ring #
1 13/16"	10,000	BX151
	15,000	BX151
2 1/16"	10,000	BX152
	15,000	BX152
2 9/16"	10,000	BX153
	15,000	BX153
3 1/16"	10,000	BX154
	15,000	BX154
4 1/16"	10,000	BX155

PSL-1 / PSL-2	(All Bore Sizes)	PSL-1 / PSL-2 / PSL-3 / PSL-3G	(All Bore Sizes 10,000 psi)
PSL-3 / PSL-3G	(Bore Sizes 2 1/16" - 4 1/16" only)	6A PSL-3 / PSL-3G	(All Bore Sizes 15,000 psi)
SSV Class 1	(All Bore Sizes)	6A SSV Class 1	(All Bore Sizes 10,000 or 15,000 psi)
SSV Class 2 - Sandy Service	(All Bore Sizes)	6A SSV Class 2 - Sandy Service	(All Bore Sizes 10,000 or 15,000 psi)

API-6A Non-NACE Trims				API-6A NACE Trims						
API Mat'l Class	AA	BB	CC	DD	EE-0,5	EE-1,5	EE	FF-0,5	FF-1,5	FF
Service	General	General	General	Sour	Sour	Sour	Sour	Sour	Sour	Sour
Trim	Standard	SS Trim	Full SS	Standard	SS Trim	SS Trim	SS Trim	Full SS	Full SS	Full SS
Corrosive	No	Slightly	Moderate	No	Moderate	Moderate	Moderate	Highly	Highly	Highly
Avail API Temp	L to X	L to X	P to X	L to X	L to X	L to X	L to X	P to X	P to X	P to X

Technical Notes

1	Nitriding is standard on all gates and seats. Tungsten Carbide, HF6 or other hardfacing techniques are also available.
2	Corrosion resistant alloy per NACE MR0175/ISO 15156.
3	Valves with API Temp Rating of X or Y will have the working pressure de-rated as per API 6A, Annex G
4	Teflon inserts on seat faces are standard in Omni valves. Metal-to-metal seats are available upon request.
5	Charpy impact test results are provided as required by API according to the temperature rating and material class.
6	Materials for sour service trims conform to latest edition of NACE MR0175. The acceptable limit of H2S should be noted after the trim level designation. Materials of construction for 0,5 and 1,5 are shown in the chart above however other partial pressure limits up to and including No Limit are available upon request. If an acceptable level is not noted in the valve trim/API Material Class designation it is understood to be "No Limit". 0,5 = 0.5 psi maximum limit of partial pressure of hydrogen sulfide 1,5 = 1.5 psi maximum limit of partial pressure of hydrogen sulfide
7	Omni reserves the right to use material class ZZ when customers request materials of construction that do not comply with current NACE MR0175/ISO standards.
8	Valves with API Temp Rating of X or Y will have high-temperature graphite packing and metal-to-metal sealing.

Model DX with PCX Self-Contained Control System



PCX Features & Details

The Omni Model PCX (pneumatic control system) is a tool designed to enhance the functionality of surface safety valves with pneumatic actuators. It can be used to automate emergency shutdown (ESD) logic, implement remote valve control features, and provide valve position feedback information to wellsite data acquisition (SCADA) systems.

The PCX system has a modular design consisting of a required "Core" ESD Module and optional modules that provide additional features. The feature set of each system "as delivered" can be customized based on end user preference or specific wellsite requirements by either adding functional modules or by adjusting the individual components used within a particular module.

The system mounts to any valve with an Omni Model DX actuator, but can easily be adapted to fit valves with actuators from other manufacturers.

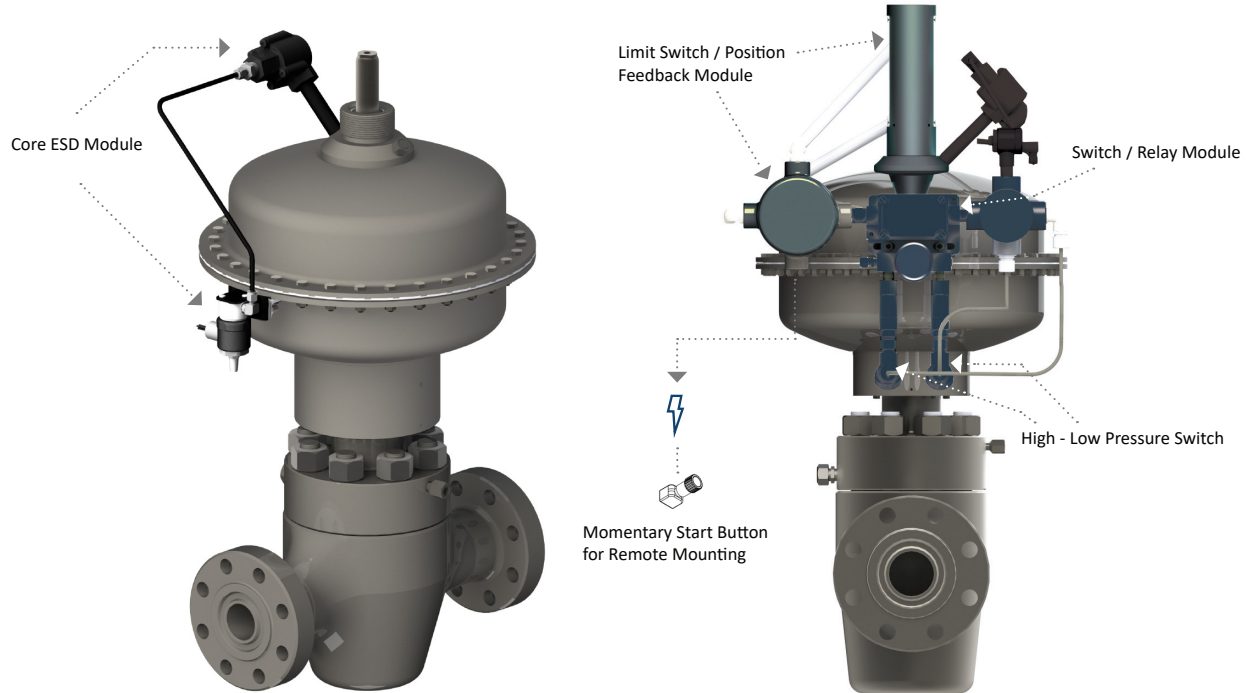

Core ESD Module	Adjustable Components	Standard Configuration	Options
-----------------	-----------------------	------------------------	---------

Provides basic ESD functionality and remote control. The safety valve will automatically close upon loss of signal power to the solenoid or may be intentionally closed by terminating the solenoid signal via PLC or other wellsite control system.

» Solenoid Valve	» 24 vDC - 1.8 Watt	» 12 vDC / Customer Specified
» Quick Exhaust Valve	» 1/2" NPT - 3/4" Exhaust	» Customer Specified

Limit Switch / Position Feedback Module	Adjustable Components	Standard Configuration	Options
---	-----------------------	------------------------	---------

Provides safety valve position information to wellsite SCADA system. Open, Closed, or both positions can be monitored. The integrated junction box allows entire system to be operated via (1) electrical connection and (1) control pressure supply connection.

» Proximity Switch	» Euroswitch F-B - Globally Certified Haz Loc	» Topworx M73 / Customer Specified
» Conduit	» Eaton Crouse-Hinds - Electri-Flex EF11-500	» Customer Specified

High - Low Pressure Switch / Relay Module	Adjustable Components	Standard Configuration	Options
---	-----------------------	------------------------	---------

Provides basic ESD functionality and remote control. The safety valve will automatically close upon loss of signal power to the solenoid or may be intentionally closed by terminating the solenoid signal via PLC or other wellsite control system.

» Low Pressure Switch	» Electronic - SST/NACE (50 - 500 psi)	» Customer Specified Range / PSL
» High Pressure Switch	» Electronic - SST/NACE (300 - 1,200 psi)	» Customer Specified Range / PSH
» Pressure Gauge	» 2.50" - Liquid Filled	» Customer Specified Range
» Flow Line Pressure Connection	» 1/4" NPT to 3/8" Compression	» Customer Specified
» Low Pressure Switch Override	» 24 vDC Relay w/Remote Mount Override	» Customer Specified / Local Mount



PNEUMATIC ACTUATORS

Omni Valve

4520 Chandler Road | Muskogee, OK | 74403 - USA

-  (918) 687-6100
-  (918) 687-6105
-  sales@omnivalve.com
-  quality@omnivalve.com

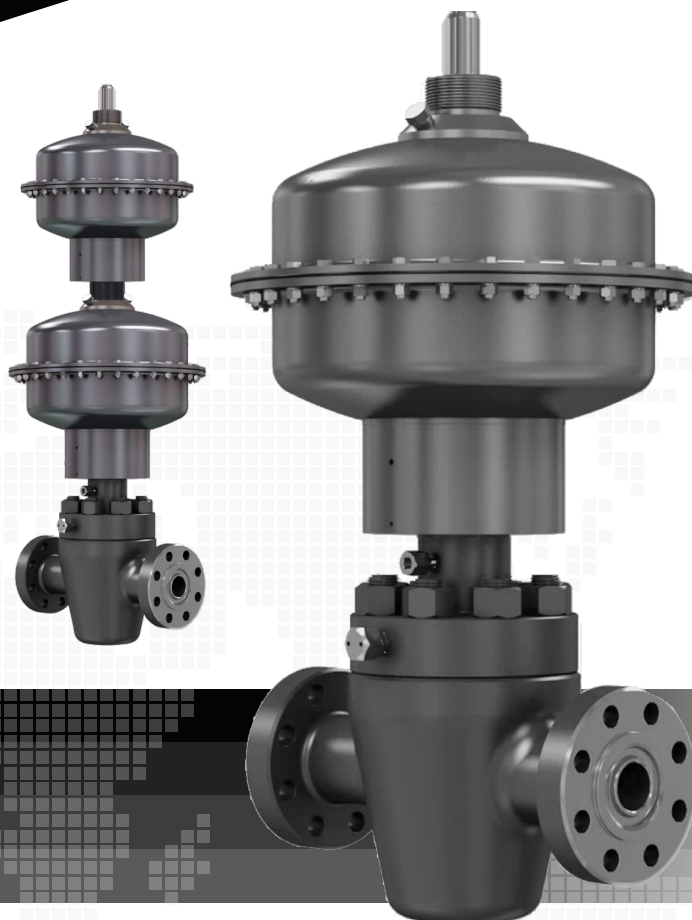

RFQ REQUEST FOR QUOTE
omnivalve.com/rfq.php

Product Warranty

All products quoted are subject to omni valve's limited product warranty available at: omnivalve.com/warranty.php